

DX-D 100 WITH WIRELESS DETECTOR

MOBILE DR SOLUTION

WITH ITS EXCELLENT IMAGE QUALITY AND FLEXIBLE HANDLING, THE MOBILE DX-D 100 WITH WIRELESS DETECTOR OFFERS FAST IMAGING THAT CAN BE VALIDATED IMMEDIATELY.

Patients who most need imaging exams may lack the mobility necessary to move to the X-ray room or to position themselves properly for optimum imaging. This is where Agfa HealthCare's mobile DX-D 100 with wireless detector comes into its own. Designed for bedside use, DX-D 100 can handle a broad range of general radiography X-ray studies, even for the least mobile patients. The very short exposure time means images are available immediately and can be validated straight away after exposure. The higher productivity and image quality translate into lower cost per exam and higher diagnostic efficiency.

What's more, the higher image quality also means potential dose reduction for patients and operators. With superb handling capabilities, it reduces waiting times and increases diagnostic confidence. The wireless detector enhances the high flexibility, while improving infection control. The DX-D 100 further answers the need for constant enhancement of patient comfort and performance of your radiology department.

- Fast assessment of images after exposure
- Improved patient and operator comfort
- Increased productivity, for lower cost per exam
- Higher image quality, for improved diagnostic effectiveness
- Dose reduction potential for all users, in particular in pediatric and neonatal environments
- Easy to operate and position both precisely and safely, with wireless portable DR detector and motorized control
- MUSICA processing for superior contrast detail and exam-independent, consistent image quality
- Superior connectivity to PACS, HIS/RIS and imagers
- High, effective generator power, for shorter exposure times and sharper images
- Very large battery capacity due to separate battery packs for driving and imaging, enabling long autonomy
- Wireless detector for improved flexibility and infection control



DX-D 100 WITH WIRELESS DETECTOR

On the go: easy handling for radiology exams

The DX-D 100 with wireless detector has been designed to offer full mobility combined with excellent image quality. Depending on your needs, you can either choose the DX-D 30C, the more compact DX-D 35C or even both. The large servo-driven wheels and small width of the unit ensure effortless handling of the DX-D 100 around the patient, even in very small areas.

Wireless mobility offers improved flexibility and infection control

The wireless capability of this mobile solution further increases the already excellent flexibility, improving your overall workflow. And with no trailing cable, there is less chance of picking up dirt or germs from the floor, making the DX-D 100 with wireless detector ideal for use in the ICU, pediatrics and neo-natal areas.

View images immediately after exposure

Thanks to the very fast preview times, images can be viewed immediately to verify right away that no retake is necessary, without moving either the patient or the DX-D 100. But the DX-D 100 doesn't trade quality for speed and portability: 125 µm pixels give the highest resolution of a full-size a-Si detector, at the patient's bedside.

Reliable and effective power

The DX-D 100 with wireless detector has a unique split battery for the generator and the motor, offering a long up-time. Even while recharging, it can make images, eliminating recharge downtime. What's more, the powerful X-ray generator gives sharper images, especially in dense areas, making it ideal for abdomen and spine examinations as well as examinations of bariatric patients.

MUSICA: tuned for the best results

The 'gold standard' MUSICA image processing has been specially adapted and tuned to further enhance the excellent DR image quality. Exam-independent, it ensures consistent image quality and high contrast detail. Time after time the superior image quality also gives the potential for significant dose reduction without the need for manual adjustments, especially important in pediatrics and neonatal.

The intuitive NX workstation: a more efficient workflow

An NX workstation with a large 17" touch screen is integrated into the DX-D 100 for optimal workflow. When a specific type of exam is selected, the appropriate X-ray settings are automatically transferred to the X-ray generator and displayed on the touch-screen console. NX adds the exposure parameters used to the digital image file, and communicates seamlessly with PACS, HIS and RIS, eliminating manual data entry and typographical errors.

A quick and easy way to go Direct Digital!

With the DX-D 100, you can enjoy the productivity benefits of Direct Digital, including a lower cost per exam. The immediate image acquisition permits a faster exam time, with improved operator productivity and patient comfort. Patients also benefit from shorter waiting times, higher diagnostic confidence and lower doses.

Services & Support

Agfa HealthCare offers service agreement solutions tailored to the individual customer's situation. The service agreements are available in Basic, Comfort and Advanced levels, making lifecycle costs predictable.

A worldwide team of some 1,000 service professionals is at your disposal to provide support at all phases of your project. As an additional service, they can help you customize your examination tree or link RIS protocol codes, for an even higher return on investment. Furthermore, this team carries out tasks that go well beyond maintenance, including value added services such as super user training, staff training and software upgrades.

Technical Specifications

STANDARD UNIT

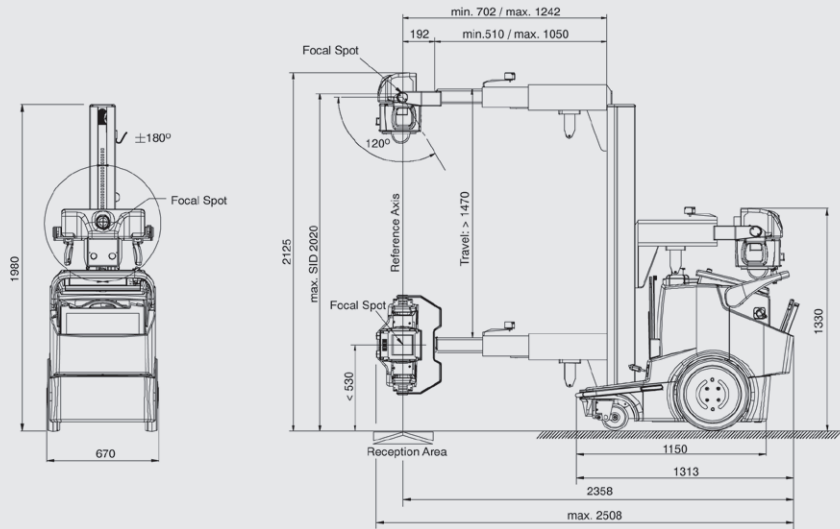

Dimensions in mm.
Tolerance in Dimensions $\pm 1\%$

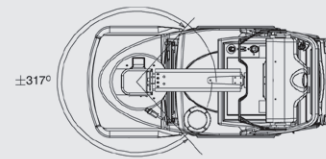
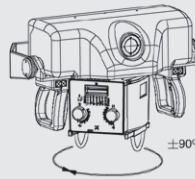

UNIT WITH TELESCOPIC COLUMN

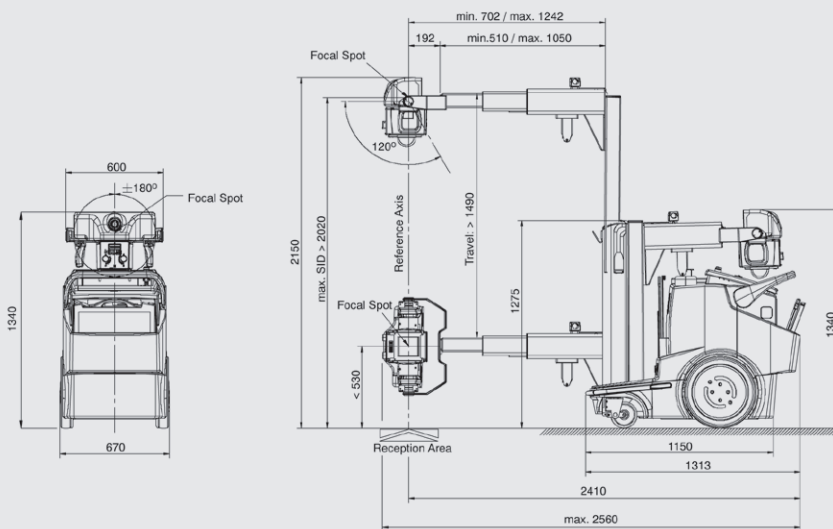

Dimensions in mm.
Tolerance in Dimensions $\pm 1\%$

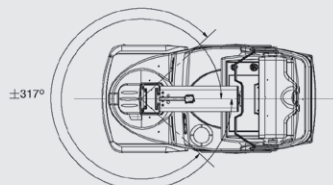
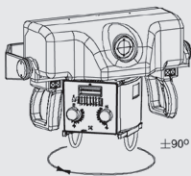

Technical Specifications

X-RAY GENERATOR

- kW: 20 kW, 32 kW, 40 kW, 50 kW
- kVp range*: 40 to 150 kVp
- mA range*: 10 - 500 mA selectable
- Exposure time range: 0.001 - 10 sec.
- mAs range*: 0.1 - 500 mAs

TUBE ARM/STAND

- Counterbalanced tube arm
- Tube arm reach: 49.2 inch (1,250 mm)
- Column rotation: $\pm 315^\circ$
- Maximal SID to floor: 80.7 inch (2,050 mm)
- Minimal SID to floor: 21.6 inch (550 mm)

MOBILE UNIT

- Weight: 1,268 lbs (575 kg) standard unit, 1,312 lbs (595 kg) unit with telescopic column
- Size (L x W x H):
 - Standard: 53.54 x 26.4 x 77.9 inch (1,360 x 670 x 1,980 mm)
 - Reduced column height: 72.44 inch (1,840 mm)
 - Unit with telescopic column: 52.75 inch (1,340 mm)
- Touch screen console: 17 inch (430 mm) diagonal
- Anti-collision system: Frontal
- Motorized unit: Up to 4 km/h
- Line requirements: Standard grounded outlet 100-240 Vac ($\pm 10\%$)
- Max. input power: 1.5 kVA
- Motor Drive (Standard): Two (2) independent drive motors, one for each wheel (forward and reverse)
- Battery systems: Two (2) independent systems for driving and imaging
- Collimator: Manual collimator

* Depending on generator model

WIRELESS PORTABLE

DX-D 30C/DX-D 35C DETECTOR

- Receptor type: Amorphous Silicon Detector (a-Si)
- Conversion screen: CsI
- Pixel pitch: 125 μm
- Wireless data transmit from detector to access point: IEEE 802.11n
- Detector comes standard with 2 batteries & 1 battery charger
- Recharge time detector battery: 3 hours
- Battery performance detector: up to 800 images (@ 15 s cycle, 1 s sleep) or 140 images (@ 100 s cycle, 1 s sleep) without recharging

DX-D 30C DETECTOR

- Pixel area: 16.77 x 13.78 inch (42.6 x 35 cm)
- Pixel matrix: 9.5 million pixels (3,408 x 2,800)
- Detector size (L x W x H): 18.1 x 15.1 x 0.6 inch (46 x 38.4 x 1.5 cm) (to ISO 4090)
- Detector weight: 7.5 lbs (3.4 kg) (incl. battery)

DX-D 35C DETECTOR

- Pixel area: 10.77 x 13.78 inch (27.4 x 35 cm)
- Pixel matrix: 6.1 million pixels (2,192 x 2,800)
- Detector size (L x W x H): 15.1 x 12.1 x 0.6 inch (38.4 x 30.7 x 1.5 cm) (ISO 4090)
- Detector weight: 5.1 lbs (2.3 kg) (incl. battery)

OPTIONS

- Telescopic column: height 52.75 inch (1,340 mm)
- Shorter column height: 72.44 inch (1,840 mm)
- IR remote control
- Dose Area Product Meter
- Anti-scatter grid with handle
- Magnetic holders:
 - packet of gloves
 - bottle of hand sanitizer
 - pack of sanitary wipes
- Collimator with double laser for optical SID

GENERATOR VERSIONS

■ Maximum power kW	20 kW	32 kW	40 kW	50 kW
■ Maximum mA	320 mA	500 mA	500 mA	500 mA
■ Minimal kVp	40 kVp	40 kVp	40 kVp	40 kVp
■ Maximum kVp	125 kVp	150 kVp	150 kVp	150 kVp
■ Power Output (@ 0.1 s)	320 mA @ 62 kVp	500 mA @ 64 kVp	500 mA @ 80 kVp	500 mA @ 100 kVp
	250 mA @ 80 kVp	400 mA @ 80 kVp	400 mA @ 100 kVp	400 mA @ 125 kVp
	200 mA @ 100 kVp	320 mA @100 kVp	320 mA @125 kVp	320 mA @ 150 kVp
	160 mA @ 125 kVp	250 mA @128 kVp	250 mA @150 kVp	
■ Compatible X-ray Tubes	E7865X	E7865X	E7884X	E7884X
		E7884X		

X-RAY TUBES

Type	E7865X	E7884X
■ Nominal voltage	150 kV	150 kV
■ Nominal focus spot value	0.3 mm/1 mm	0.6 mm/1.2 mm
■ Nominal power small focus	3.2 kW	20 kW
■ Nominal power large focus	36.5 kW	50 kW
■ Anode target angle	12°	12°
■ Anode diameter	74 mm	74 mm
■ Anode heat content	100 kJ (140 kHU)	210 kJ (300 kHU)
■ Anode rotation speed	Minimum 3200 min-1	Minimum 3200 min-1

DX-D 100 WITH WIRELESS DETECTOR

Agfa HealthCare is a global leader in the fast growing market of integrated IT and imaging systems, offering healthcare facilities a seamless flow of information and a 360° view of patient care. The company has a unique, holistic approach, enabling it to provide in-depth clinical know-how and fully integrated hospital-wide solutions. These specialized solutions integrate IT and imaging systems for Radiology, Cardiology, Mammography and Orthopaedics. Agfa HealthCare's enterprise-wide IT platform integrates all administrative and clinical data within a healthcare facility and is designed to match the unique needs of specific healthcare professionals. ■

www.agfahealthcare.com

Agfa and the Agfa rhombus are trademarks of Agfa-Gevaert N.V., Belgium, or its affiliates. MUSICA and DX are trademarks of Agfa HealthCare NV, Belgium or its affiliates. All other trademarks are held by their respective owners and are used in an editorial fashion with no intention of infringement. The data in this publication are for illustration purposes only and do not necessarily represent standards or specifications, which must be met by Agfa HealthCare. All information contained herein is intended for guidance purposes only, and characteristics of the products and services described in this publication can be changed at any time without notice. Products and services may not be available for your local area. Please contact your local sales representative at agfa.com for availability information. Agfa HealthCare diligently strives to provide as accurate information as possible, but shall not be responsible for any typographical error.

© 2015 Agfa HealthCare NV
All rights reserved
Printed in Belgium
Published by Agfa HealthCare NV
B-2640 Mortsel – Belgium
5SBHZ GB 00201507